

REPAIR INSTRUCTIONS

HYDRONIC S3 ECONOMY

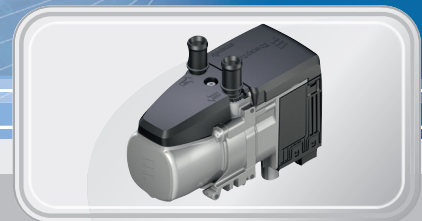

VALID FOR THE FOLLOWING WATER HEATERS:

Heaters for petrol	Order No.	→ 07/2017	→ 05/2020	05/2020 →
B 4 E – 12 V CL		20.1963.05.0000	20.1994.05.0000	20.2049.05.0000
B 5 E – 12 V CL		20.1952.05.0000	20.1993.05.0000	20.2048.05.0000
Heaters for diesel				
D 4 E – 12 V CL		25.2694.05.0000	25.2913.05.0000	25.2989.05.0000
D 5 E – 12 V CL		25.2652.05.0000	25.2912.05.0000	25.2971.05.0000
D 5 E – 12 V CI-Bus			25.2984.05.0000	25.2996.05.0000
Heaters for diesel				
with inlet pressure resistant metering pump				
D 4 E – 12 V CL			25.2922.05.0000	25.2991.05.0000
D 5 E – 12 V CL			25.2921.05.0000	25.2990.05.0000

CONTENTS

CHAPTER	CHAPTER TITLE	PAGE	CHAPTER CONTENTS
1	INTRODUCTION		
	General information	5	
	Other applicable documents	5	
	• Technical description	5	
	• Spare parts list	5	
	• Installation recommendation	5	
	• Installation Instructions Plus	5	
	Safety instructions	5	
	Warranty and Liability	5	
	Accident prevention	5	
	Functional test following a repair	5	
	Emergency shutdown – EMERGENCY OFF	5	
2	TROUBLESHOOTING		
	What to check first in case of faults	6	
	Control box locked	6	
	• The control box is locked if the following faults occur:	6	
	Unlock control box	6	
	Overview of testing equipment / control units	6	
	External diagnostics system	6	
	Fault diagnosis using the control unit	6	
	Fault code table	7	
3	REPAIR INSTRUCTIONS		
	Special tool	12	
	• Control box dismantling kit	12	
	• Release tool	12	
	Repair steps	13	
	Dismantle the heater	13	
	Repair step 1	13	
	• Remove the control box	13	
	• Renew the electric motor cover	14	
	Repair step 2	15	
	• Remove the sensor cover and water connection socket	15	
	Repair step 3	15	
	• Remove the heat exchanger	15	
	Repair step 4	15	
	• Remove combustion chamber	15	

CONTENTS

Repair step 5	16
• Remove the lead harness of the heater	16
• Check flame sensor	16
• Check the water inlet and outlet sensor	16
Repair step 6	17
• Dismantle glow plug	17
• Check the glow plug	17
Repair step 7	17
• Replace the blower	17
Repair step 8	17
• Remove the blower housing / heat exchanger seal and the fuel connection grommet	17
Assemble the heater	18
Install the fuel connection grommet and blower housing / heat exchanger seal	18
Install the glow plug	18
Install the lead harness of the heater / flame sensor	19
Install the combustion chamber	19
Installing the heat exchanger	19
Install the water inlet sensor / water outlet sensor	19
Install water connection socket / sensor cover	20
Mounting the control box	20
Installing the blower cover	20
Measuring the fuel quantity	21
• Preparing for the measurement	21
• Measurement	21
Evaluation	21
Measuring the fuel quantity, with EasyScan	21
• Preparation / measurement / evaluation	21
Hydronic S3 Economy component drawing	22
4 ELECTRICS / CIRCUIT DIAGRAM	
Heater wiring	23
Parts list for circuit diagram, heater and cable harness	23
Heater circuit diagram	24
Cable harness circuit diagram	25
5 TECHNICAL DATA	
Petrol heater	26
Diesel heater	27

CONTENTS

6	ENVIRONMENT	
	Certifications	28
	Disposal	28
	• Disposal of materials	28
	• Dismantling the heater	28
	• Packaging	28
7	SERVICE	
	Standard times	29
	Index	30
	List of abbreviations	31

1 INTRODUCTION

GENERAL INFORMATION

This documentation applies to the heaters listed on the title page, to the exclusion of all liability claims.

Depending on the version or revision status of the heater, differences may occur compared to this documentation.

Check this before carrying out the repair and take into account possible differences.

This documentation is to be used to correct faults and to carry out repairs on the heater. The necessary work may only be carried out by personnel appropriately trained by an Eberspächer service partner.

OTHER APPLICABLE DOCUMENTS

TECHNICAL DESCRIPTION

Describes the function and proper installation and contains all information necessary for safe operation of the heater.

SPARE PARTS LIST

Contains the information necessary for ordering spare parts.

INSTALLATION RECOMMENDATION

Describes the installation situation appropriate for the vehicle type.

INSTALLATION INSTRUCTIONS PLUS

Information on heaters and control units.

SAFETY INSTRUCTIONS



DANGER!

Fire hazard. Risk of poisoning due to exhaust gases.

Improper repair or installation can result in toxic exhaust gases getting into the interior of the vehicle or a fire.

- Repair and installation of the heater by authorised and trained skilled personnel only.
- Use original spare parts only.
- Comply with the official regulations.
- Take into account and follow this document and all applicable documentation.



NOTE

- Comply with the vehicle manufacturer's instructions.
- In case of electric welding work on the vehicle, disconnect the positive pole from the battery and connect it to ground.

WARRANTY AND LIABILITY

Eberspächer Climate Control Systems GmbH does not accept any liability whatsoever for defects and damage, which are due to installation or repair by unauthorised and untrained persons.

Compliance with the official regulations and the safety instructions is prerequisite for liability claims.

Failure to comply with the official regulations and safety instructions leads to exclusion of any liability of the manufacturer.

ACCIDENT PREVENTION

Always follow all accident prevention regulations and shop and operating safety instructions.

FUNCTIONAL TEST FOLLOWING A REPAIR

- Vent the coolant circuit and the whole fuel supply system. Comply with the instructions issued by the vehicle manufacturer.
- Open all heating circuits before the trial run (set the temperature control to “warm”).
- Switch on the heater at the control unit and during the trial run check all water and fuel connections for leaks and tight fit.
- Correct any faults during operation with the help of diagnostic equipment or the control unit.



NOTE

- The function of the heater is described in detail in the “Technical Description” document.

EMERGENCY SHUTDOWN – EMERGENCY OFF

In an emergency carry out an emergency shutdown as follows:

- Switch off the heater at the control unit or disconnect it from the power supply (remove fuse / disconnect battery).

2 TROUBLESHOOTING

WHAT TO CHECK FIRST IN CASE OF FAULTS

- **Check**
 - Fuel in the tank?
 - Fuel lines filled? (Visual check)
 - In the case of a diesel heater: summer diesel still in the fuel lines?
 - Heater controller (water valve) fully set to “warm”?
 - Combustion air system or exhaust system damaged or blocked?
- **Electrical components**
 - Cables, connections damaged?
 - Contacts corroded?
 - Fuses defective?
 - Faulty wiring (short circuit, interruption)?
- **Check battery voltage**
 - Undervoltage protection ON (battery voltage < 10.5 V)?
 - Overvoltage protection ON (battery voltage > 16 V)?
- **Check voltage supply UBatt (Terminal 30)**
 - Unplug the 2-pin connector -XB1 from the heater.
 - Measure the voltage between cable RD (chamber 1) and cable BN (chamber 2) in the 2-pin connector -XB1.

In case of a voltage deviation, check the following components for corrosion or interruption:

 - Fuses
 - Supply lines
 - Earth connections
 - Battery terminal posts

CONTROL BOX LOCKED

THE CONTROL BOX IS LOCKED IF THE FOLLOWING FAULTS OCCUR:

- **Unsuccessful start attempts**

Following 3 consecutive failed start attempts, [see Fault code P00012B \(050\)](#).
- **Overheating**

Following three overheating cutouts, [see Fault code P00011A \(015\)](#).

UNLOCK CONTROL BOX

The control box can be unlocked with testing equipment / a control unit. For the procedure and description for testing equipment and for control units see “Installation Instructions Plus – EasyStart/Altitude Kit, Special Functions and Diagnosis”.

OVERVIEW OF TESTING EQUIPMENT / CONTROL UNITS

The electronic control box can store up to 5 faults. The current fault AF and the stored faults “F1” to “F5” can be read out, displayed and deleted. It is possible to read out, display and delete the fault memory and to unlock the control box with the following testing equipment / control units:

Test equipment	Order No.
▪ EasyScan diagnostic tool	22 1550 89 00 00

Control unit	Order No.
▪ EasyStart Timer	22 1000 34 15 00
▪ EasyStart Remote+	22 1000 34 17 00
▪ EasyStart Select	22 1000 34 13 00
▪ EasyStart Web	22 1000 34 51 00

NOTE

The diagnostics cable (BUWH) must be connected for control units. Unable to read out fault memory:

- Check the diagnostic cable for correct connection and / or damage.

EXTERNAL DIAGNOSTICS SYSTEM

If an external diagnostics system is to be used, contact the vehicle manufacturer.

FAULT DIAGNOSIS USING THE CONTROL UNIT

Fault diagnosis with control units is described in detail in the applicable document “Installation Instructions Plus – EasyStart/Altitude Kit, Special Functions and Diagnosis”.

After activating the control unit, faults are displayed during heating mode with “Err”.



The current fault AF and the stored faults “F1” to “F5” can be read out, displayed and deleted.

NOTE

- For further information and up-to-date circuit diagrams of the control units, see “Installation Instructions Plus” in the Eberspächer Service Portal.
- The BUWH cable must be connected to perform the diagnosis. To do this, follow the control unit and heater circuit diagrams.
- If the diagnostics cable BUWH is not connected, the “Diagnosis” menu is blocked.
- Not only the defective component, but also a defective current circuit results in a fault or error message.
- Fault code, fault description, cause / remedial action are described [from page 7](#).
- Ensure adequate battery voltage (> 10.5 V).

2 TROUBLESHOOTING



FAULT CODE TABLE

FAULT CODE P000... for EasyScan (...) for TP 7	FAULT DESCRIPTION	CAUSE ▪ REMEDIAL ACTION
P000100 (071) P000101 (072)	Water outlet sensor – Interruption – Short circuit	<ul style="list-style-type: none"> ▪ Check the water outlet sensor. <ul style="list-style-type: none"> – Check cables for continuity, short circuit and damage. – Unplug connector XB4, measure resistance between cable RD (chamber 9) and cable RD (chamber 10). <ul style="list-style-type: none"> > Measured values see page 17, deviating values → renew lead harness of heater.
P00010A (051)	Cold air – timeout	The combustion chamber has not cooled sufficiently for a restart. <ul style="list-style-type: none"> ▪ Check whether hot combustion air is drawn in, if not → check the flame sensor, see Fault code P000120 (064) and Fault code P000121 (065).
P000110 (060) P000111 (061)	Water inlet sensor – Interruption – Short circuit  NOTE! Fault code P000110 (060) and P000111 (061) are displayed only if <ul style="list-style-type: none"> ▪ the heater is in operation ▪ temperature reached at water outlet sensor at least 80 °C. 	<ul style="list-style-type: none"> ▪ Check the water inlet sensor. Check cables for continuity, short circuit and damage. <ul style="list-style-type: none"> – Unplug connector XB4, measure resistance between cable BU (chamber 5) and cable BU (chamber 6). <ul style="list-style-type: none"> > Measured values see page 17, deviating values → renew lead harness of heater.
P000114 (014)	Possible risk of overheating (implausible signal)  NOTE! Fault code P000114 (014) is displayed only if <ul style="list-style-type: none"> ▪ the heater is in operation ▪ temperature reached at water outlet sensor at least 80 °C. 	Too large temperature difference between the water inlet and water outlet sensor. <ul style="list-style-type: none"> ▪ For remedial action see Fault code P000115 (012). ▪ Check the water inlet sensor. <ul style="list-style-type: none"> – Unplug connector XB4, measure resistance between cable BU (chamber 5) and cable BU (chamber 6). <ul style="list-style-type: none"> > Measured values see page 17, deviating values → renew lead harness of heater.
P000115 (012)	Overheating – software threshold exceeded	Temperature at the water outlet sensor >125 °C. <ul style="list-style-type: none"> ▪ Check water circuit for leaks (heater controller in warm position) ▪ If non-return valve / thermostat in the water circuit, check the flow direction. ▪ Check water throughput rate. ▪ Vent water circuit. ▪ Check the water outlet sensor <ul style="list-style-type: none"> – Check cables for continuity, short circuit and damage. – Unplug connector XB4, measure resistance between cable RD (chamber 9) and cable RD (chamber 10). <ul style="list-style-type: none"> > Measured values see page 17, deviating values → renew lead harness of heater. ▪ Check water pump, see Fault code P000253 (044) to Fault code P000258 (046).

2 TROUBLESHOOTING

FAULT CODE P000... for EasyScan (...) for TP 7	FAULT DESCRIPTION	CAUSE ▪ REMEDIAL ACTION
P000116 (017)	Overheating – hardware threshold exceeded	Temperature at the water outlet sensor >130 °C. <ul style="list-style-type: none"> ▪ For remedial action see Fault code P000115 (012). ▪ Check the water outlet sensor. <ul style="list-style-type: none"> – Check cables for continuity, short circuit and damage. – Unplug connector XB4, measure resistance between cable RD (chamber 9) and cable RD (chamber 10). <ul style="list-style-type: none"> > Measured values see page 17, deviating values → renew lead harness of heater.
P00011A (015)	Operating lock-out – too many overheating events detected	The control box is locked due to too frequent consecutive overheating (Fault code P000114 (014) , Fault code P000115 (012)). <ul style="list-style-type: none"> ▪ For remedial action see Fault code P000114 (014), Fault code P000115 (012). ▪ Unlock control box, see page 6.
P000120 (064) P000121 (065)	Flame sensor interruption Short circuit in flame sensor	<ul style="list-style-type: none"> ▪ Check flame sensor. <ul style="list-style-type: none"> – Check cable for continuity, short circuit and damage. – Unplug connector XB4, measure resistance between cable BN (chamber 7) and cable BN (chamber 8). <ul style="list-style-type: none"> > Measured values see page 16, deviating values → renew lead harness of heater. ▪ Next display Fault code P000120 (064), Fault code P000121 (065) → renew control box, see Repair step 1, Page 13.
P000125 (057) P000126 (056) P000127 (055) P000128 (054) P000129 (053)	Flame cutout from start process Flame cutout within the control range 0% – 25% Flame cutout within the control range 25% – 50% Flame cutout within the control range 50% - 75% Flame cutout within the control range 75% - 100%  NOTE! In case of flame cutout during the start phase or in normal operation the heater is restarted (max. 3 times). If the restart was successful, the fault code display is deleted.	<ul style="list-style-type: none"> ▪ Check exhaust and combustion air system. ▪ Check fuel quantity and fuel supply, see page 21. ▪ Check flame sensor, see Fault code P000120 (064) and Fault code P000121 (065).
P00012A (052)	Safety time – exceeded	<ul style="list-style-type: none"> ▪ Check exhaust and combustion air system. ▪ Check fuel quantity and fuel supply, see page 21. ▪ Renew the fuel filter. ▪ Clean the fuel filter in the connection socket of the metering pump.



2 TROUBLESHOOTING

FAULT CODE P000... for EasyScan (...) for TP 7	FAULT DESCRIPTION	CAUSE ▪ REMEDIAL ACTION
P00012B (050)	Operating lock-out, too many safety timeouts	Following three unsuccessful start attempts the control box is locked. ▪ Unlock control box, see page 6 . ▪ Check fuel quantity and fuel supply, see page 21 .
P000200 (048) P000201 (047)	Metering pump interruption Metering pump – short circuit	▪ Check metering pump lead harness for continuity, short circuit and damage. > Lead harness ok → renew the metering pump.
P000202 (049)	Metering pump – short circuit downstream of +Ub or transistor error	▪ Check cables for continuity, short circuit and damage. – Unplug the connector at the metering pump. ▪ Display Fault code P000200 (048) metering pump defective → renew metering pump.
P000210 (020) P000211 (021) P000212 (022)	Glow plug – interruption Glow plug – short circuit Glow plug – short circuit downstream of +Ub or transistor error  CAUTION! Damage to unit in case of over-voltage Voltage > 9.5 V irreparably damages the glow plug. → Test function with max. 9.5 V.  NOTE Note the short-circuit withstand capability of the power pack.	▪ Check glow plug. – Check cables for continuity, short circuit and damage. – Unplug connector -XB4, unclip cable WH (chamber 3) and cable WH (chamber 4). – Apply 9.5 V ±0.1 V voltage to the glow plug and after 25 sec measure the current intensity. > Measured value 9.5 A (+1 / -1.5) the glow plug is ok > Deviating values → renew the glow plug.
P000213 (019)	Glow plug – ignition energy too low	Glow plug energy input is too low. – Check cables for continuity, short circuit and damage. – Test glow plug, see Fault code P000210 (020) to Fault code P000212 (022) .
P000220 (031) P000221 (032) P000222 (033)	Electric motor – interruption Electric motor – short circuit Electric motor – short circuit downstream of +Ub or transistor error	▪ Measure blower speed with EasyScan diagnostic tool, see EasyScan operating instructions.
P000223 (030) P000224 (029)	Electric motor – blocking Electric motor – current input too low	Impeller blocked (frozen, soiled, sluggish, ...). ▪ Remove blockage. – Check electric motor for smooth and easy running by turning the impeller manually. ▪ Next display Fault code P000223 (030) / Fault code P000224 (029) → renew the blower, see Repair step 7, Page 17 .

2 TROUBLESHOOTING

FAULT CODE P000... for EasyScan (...) for TP 7	FAULT DESCRIPTION	CAUSE ▪ REMEDIAL ACTION
P000250 (041) P000251 (042)	Water pump – interruption Water pump – short circuit	<ul style="list-style-type: none"> ▪ Check lead harness of the water pump: <ul style="list-style-type: none"> – Unplug connector -XB3 at the heater – Unplug connector -XB8/2 at the water pump. – Check cable for continuity, short circuit and damage. <ul style="list-style-type: none"> > Lead harness of the water pump ok → renew the water pump.
P000252 (043)	Water pump - short circuit downstream of +Ub or transistor error	<ul style="list-style-type: none"> ▪ Unplug connector -XB8/2 at the water pump. <ul style="list-style-type: none"> > Display Fault code P000250 (041) Water pump defective → renew water pump.
P000253 (044)	Water pump – blocking	<ul style="list-style-type: none"> ▪ Water hoses laid free from kinks?
P000254 (044)	Water pump – overcurrent cutout	<ul style="list-style-type: none"> ▪ Water pump / water circuit dirty?
P000255 (044)	Water pump – speed below minimum	<ul style="list-style-type: none"> ▪ Water pump / water circuit dirty?
P000256 (045)	Water pump – dry running	<ul style="list-style-type: none"> ▪ Check the coolant liquid level in the water circuit. ▪ Vent the water pump / water circuit.
P000257 (045)	Water pump – overheating	<ul style="list-style-type: none"> Water pump ambient temperature too high. ▪ Position the water pump at an adequate distance from hot vehicle parts.
P000258 (046)	Water pump – undervoltage / overvoltage	<ul style="list-style-type: none"> ▪ Check lead harness of the water pump: <ul style="list-style-type: none"> – Unplug connector -XB3 at the heater – Unplug connector -XB8/2 at the water pump. – Check cable for continuity, short circuit and damage. <ul style="list-style-type: none"> > Lead harness of the water pump ok → renew the water pump.
P000261 (039)	Vehicle blower – short circuit	<ul style="list-style-type: none"> ▪ Check electric motor cover for damage and correct fit. <ul style="list-style-type: none"> > Electric motor cover ok → renew blower relay -K1.
P000300 (074)	Overheating detection Metering pump hardware or cutout circuit defective	<ul style="list-style-type: none"> ▪ Check the water outlet sensor. Check cables for continuity, short circuit and damage. <ul style="list-style-type: none"> – Unplug connector XB4, measure resistance between cable RD (chamber 9) and cable RD (chamber 10). <ul style="list-style-type: none"> > Measured values see page 17, deviating values → renew lead harness of heater. ▪ Next display Fault code P000300 (074) → renew lead harness of the heater. ▪ Unlock control box, see page 6.
P000301 (090)	Control box defective	<ul style="list-style-type: none"> ▪ Replace control box, see Repair step 1, Page 13
P000302 (090)	Control box defective	
P000303 (094)	Control box defective	<ul style="list-style-type: none"> ▪ Replace control box, see Repair step 1, Page 13
P000304 (091)	Control box defective	<ul style="list-style-type: none"> ▪ Replace control box, see Repair step 1, Page 13
P000305 (096)	Control box defective	<ul style="list-style-type: none"> ▪ Replace control box, see Repair step 1, Page 13
P000306 (098)	Control box defective	<ul style="list-style-type: none"> ▪ Replace control box, see Repair step 1, Page 13

2 TROUBLESHOOTING

FAULT CODE P000... for EasyScan (...) for TP 7	FAULT DESCRIPTION	CAUSE ▪ REMEDIAL ACTION
P000310 (010) P000311 (010)	Control box cutout due to overvoltage Heater cutout due to overvoltage  NOTE! Heater is not functioning.	Overvoltage applied at the control box without interruption for at least 20 seconds. <ul style="list-style-type: none"> ▪ Unplug connector -XB1 at the heater. ▪ Start the vehicle engine. ▪ Measure voltage between cable RD (chamber 1) and cable BN (chamber 2). <ul style="list-style-type: none"> > Voltage >15 volt – Check alternator controller – Check the battery.
P000312 (011) P000313 (011)	Control box cutout due to undervoltage Heater cutout due to undervoltage  NOTE! Heater is not functioning.	Undervoltage applied at the control box without interruption for at least 20 seconds. <ul style="list-style-type: none"> ▪ Unplug connector -XB1 at the heater. ▪ Start the vehicle engine. ▪ Measure voltage between cable RD (chamber 1) and cable BN (chamber 2). <ul style="list-style-type: none"> > Voltage < 10 volt – Check the fuses, the supply cables, the ground connections and the positive terminal post at the battery for voltage drop (corrosion).
P000315	Implausible air pressure information via LIN bus (CI Bus)	<ul style="list-style-type: none"> ▪ Check the connection to the control element. ▪ If the error persists, check the control element or external air pressure sensor (both manufacturer-specific), replace if necessary.
P000330 (092)	Control box defective	<ul style="list-style-type: none"> ▪ Replace control box, see Repair step 1, Page 13
P000331 (093)	Control box defective	<ul style="list-style-type: none"> ▪ Replace control box, see Repair step 1, Page 13
P000332 (099)	Control box defective	<ul style="list-style-type: none"> ▪ Replace control box, see Repair step 1, Page 13
P000400 (082)	Stationary part of the remote control defective	<ul style="list-style-type: none"> ▪ Check power supply and fuse. ▪ If in order -> teach stationary part again. ▪ If the error persists -> replace the stationary part of the remote control
P0005000	Fault memory entry ErrorState_GSC. Fault response: Heating or ventilation mode is continued.	<ul style="list-style-type: none"> ▪ Withdrawal of the active request (fault remains active as long as heating or diagnosis request still exists). ▪ Delete fault memory.
P000A00	Communication is ended by the heater. EasyFan does not respond to the coded number of messages.	<ul style="list-style-type: none"> ▪ Reset the fault by withdrawing the active request (fault remains active as long as heating or diagnosis request exists). ▪ Delete fault memory.
P000E02	LIN communication error (CI Bus)	<ul style="list-style-type: none"> ▪ Check the connection to the control element. ▪ If the error persists, check the control element (manufacturer-specific), replace if necessary.
P000E03	LIN communication error (CI Bus)	<ul style="list-style-type: none"> ▪ Check the connection to the control element. ▪ If the error persists, check the control element (manufacturer-specific), replace if necessary.

3 REPAIR INSTRUCTIONS

This chapter describes the permitted repair work on the heater. The heater must be removed from the vehicle for the repair work to be carried out.

Assembly of the heater is described [from page 18](#).



DANGER!

Risk of injury, burns and poisoning!

Ensure the following before carrying out any work on the heater:

- Switch off the heater and leave it to cool.
- Disconnect the battery.
- Do not operate the heater in enclosed spaces (garage / workshop).
Exception: use of an exhaust extractor.



CAUTION!

Damage to the unit

- Always renew the seals and O-rings of dismantled components.
- Check all components for damage and replace if necessary.
- Check plug-in contacts, plug-in connections and cables for corrosion and damage, and repair if necessary.
- Use original spare parts only.
- After working on the coolant circuit, check the coolant level and if necessary top up according to the vehicle manufacturer's instructions.
- Then vent the coolant circuit.
- Operation and after running of the heater may only be stopped in an emergency (see "EMERGENCY OFF" [on page 20](#)) by interrupting the battery current (risk of heater overheating).



NOTE!

Thread-forming screws are used to fix the components in the factory. In case of repair the thread is already pre-cut by the initial installation.

Installation instructions

- Position screw by hand and screw in.
 - Always keep to the given tightening torque.
- When screwing for the second time also position by hand and do not cut a new thread.
- The screw is suitable for max. 6 installation attempts.



NOTE!

After completing all the work and installing the heater in the vehicle, perform a functional test of the heater, [see page 5](#).

SPECIAL TOOL

CONTROL BOX DISMANTLING KIT

Order No. 25 2652 81 10 00

The dismantling kit is required to unlock the control box and consists of a lever (1) with two release wedges (2). To use the wedges, break them off at the connection pins.

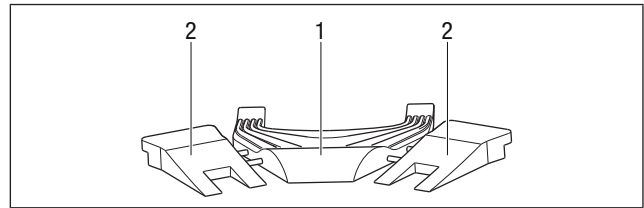

RELEASE TOOL

The release tool is used to release contacts in the connectors. The tool can be ordered directly from the manufacturer HERTH+BUSS ELPARTS.

- For tab connector 1.2 mm Order No. 959 45 400
- For tab connector / tab receptacle 2.8 mm Order No. 959 45 402

3 REPAIR INSTRUCTIONS

REPAIR STEPS

i NOTE!

This repair instruction describes how to dismantle the heater in individual repair steps. Reference is made to the necessary preceding steps to be carried out at the relevant repair steps.

Repair step 1

Remove the control box

[Page 13](#)

Renew electric motor cover

[Page 14](#)

Repair step 2

Remove sensor cover / water connection socket

[Page 15](#)

Repair step 3

Remove the heat exchanger

[Page 15](#)

Repair step 4

Remove the combustion chamber

[Page 15](#)

Repair step 5

Remove lead harness of the heater

[Page 16](#)

Check the flame sensor

[Page 16](#)

Check the water inlet sensor

[Page 16](#)

Check the water outlet sensor

[Page 16](#)

Repair step 6

Dismantle glow plug

[Page 17](#)

Check the glow plug

[Page 17](#)

Repair step 7

Replace the blower housing

[Page 17](#)

Repair step 8

Remove the blower housing / heat exchanger seal and the fuel connection grommet

[Page 17](#)

DISMANTLE THE HEATER

⚠ CAUTION!

Unit damage due to unbalance!

The impeller is pressed on precisely. If the heater is put down on the blower it can cause damage to the blower.

→ Do not lay heater on its impeller.

→ Always put down heater to the side.

REPAIR STEP 1

REMOVE THE CONTROL BOX

i NOTE!

Use the dismantling kit to remove the control box. Do not undo the bottom snap connections of the control box.

1. Undo both screws (4) from the control box (3).
2. Undo the screw (1) of the sensor cover (2) by 3 turns and lift up the sensor cover (2).
3. Release both snap connections (5) on the blower cover (6).

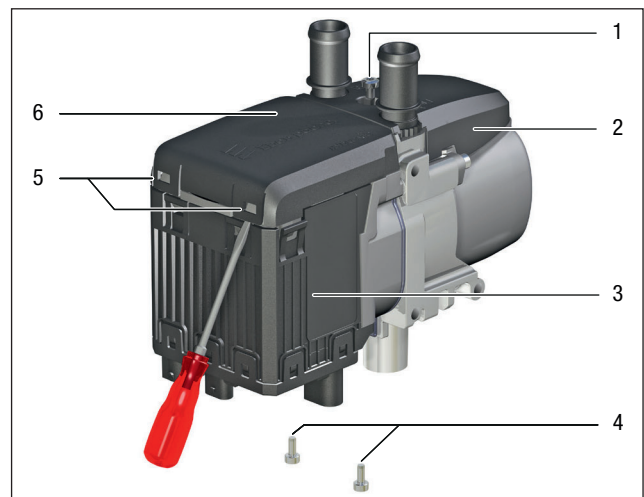

4. Lift up the blower cover (6).
5. Insert both wedges (9) between the blower cover (6) and the snap catches (10) of the control box (3), release the snap catches.
6. Insert the lever (8) in the snap catches (7) of the control box (3) and unlock the control box. To do this press the lever (8) up to the blower cover (6).

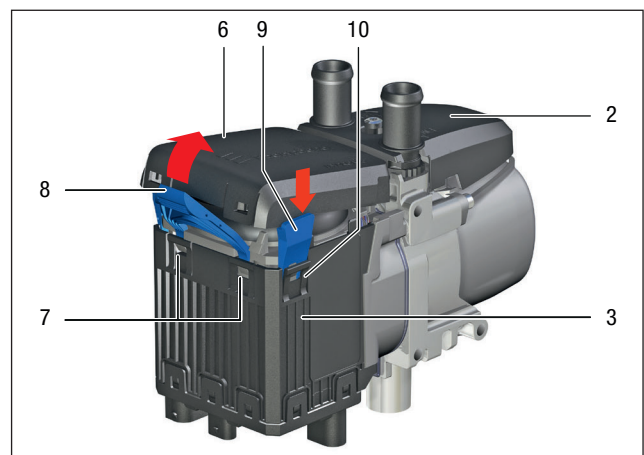

3 REPAIR INSTRUCTIONS

7. Pull off the control box (3) carefully, at the same time remove the electric motor cover (11) and the ground cable (12).
8. Unlock and unplug connector -XB4 (13).

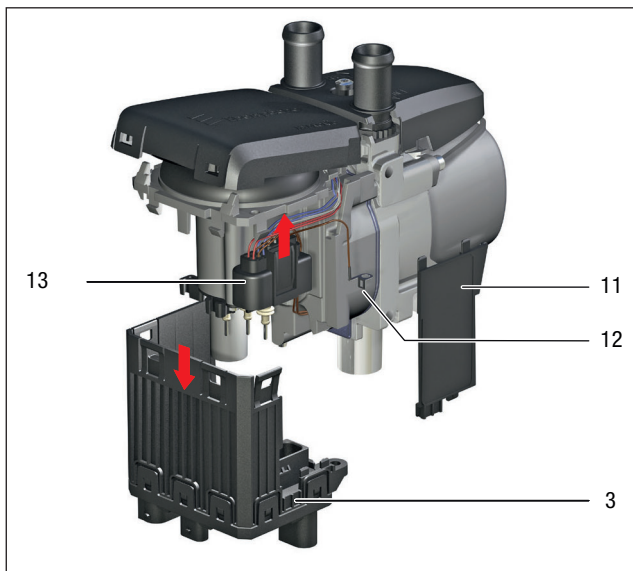

RENEW THE ELECTRIC MOTOR COVER



CAUTION!

Damage to the unit caused by leak or dirt

The seals on the electric motor cover are permanently deformed following removal of the control box. An integral seal with the control box is not ensured on re-installation.

→ Always replace the electric motor cover.

If the electric motor cover is renewed, dirt particles and metal parts can get inside the motor.

→ Install the new electric motor cover immediately.

→ For installation details, see point 12 onwards.

The electric motor cover is included in the

- kit – control box
- kit – glow plug
- kit – heater lead harness.

9. Unhook the flame sensor (19) connection cables at the guide hook (17).
10. Undo three screws (16) from the electric motor cover (15).
11. Pull the electric motor cover (15) carefully off the connection pins (18).

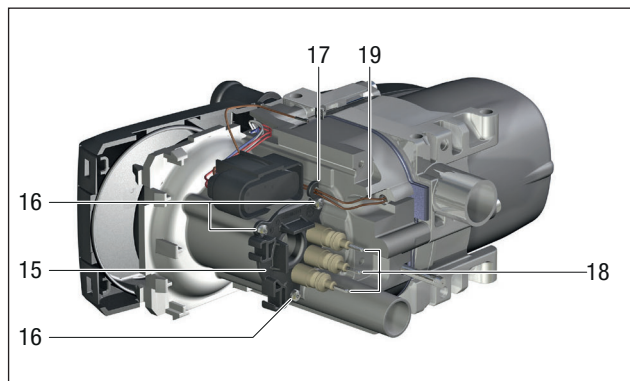

12. Push the new electric motor cover (15) carefully onto the connection pins (18) and press on lightly.



NOTE!

Do not change the position of the connection pins.

13. Screw in the 3 screws M3 × 12 (16). Tightening torque 1.5±0.1 Nm.
14. Hook the flame sensor (19) connection cables into the guide hook (17).

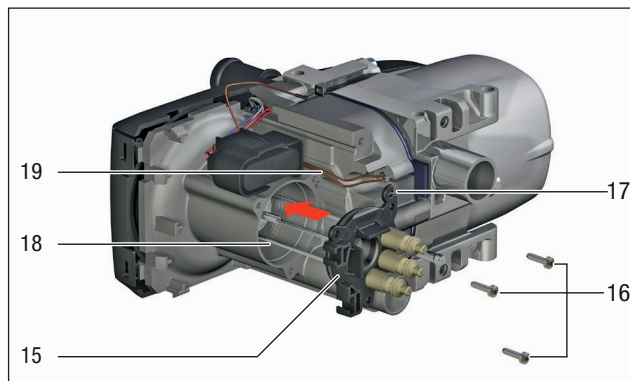

Install the control box, [see page 20](#), point 26–32.

3 REPAIR INSTRUCTIONS

REPAIR STEP 2

REMOVE THE SENSOR COVER AND WATER CONNECTION SOCKET

1. Undo the screw (1).
2. Remove the sensor cover (2) and water connection socket (3).

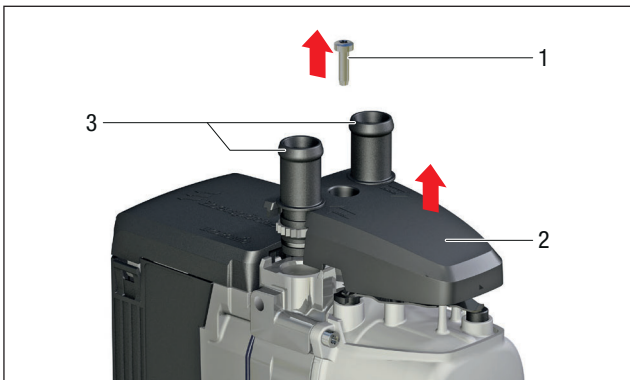

Install the sensor cover and water connection socket, [see page 20](#), point 21–32.

REPAIR STEP 3

REMOVE THE HEAT EXCHANGER

Carry out [Repair step 1](#) and [Repair step 2](#) first.

1. Undo the screw (1), remove the compression spring (2).
2. Use pliers to pull out the water inlet sensor (3) and water outlet sensor (4).
3. Undo the screws (5), pull off the heat exchanger (6).

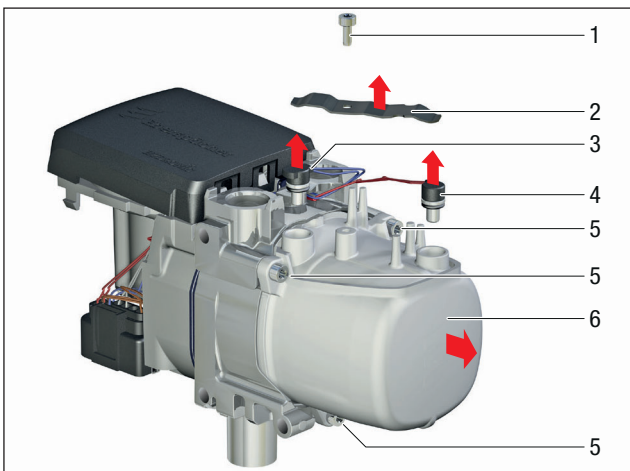

Install the heat exchanger, [see page 19](#), point 13–32.

i NOTE!

Repair step 1 is not necessary if the heat exchanger is replaced

REPAIR STEP 4

REMOVE COMBUSTION CHAMBER

Carry out [Repair step 1](#) to [Repair step 3](#) first.

1. Unlock the snap connections (1) on the blower cover (2) and remove the blower cover.

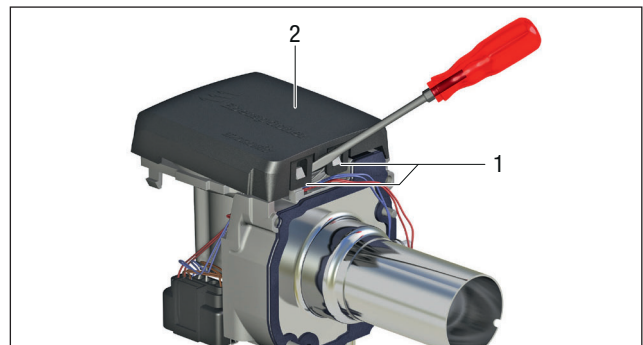

2. Pull the combustion chamber (3) together with the glow plug off the blower housing.

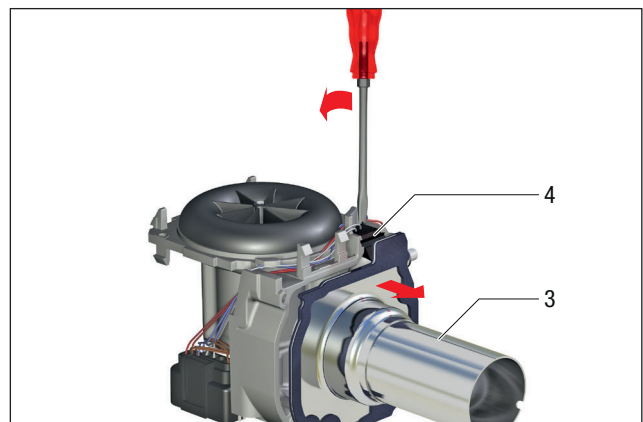

3. Pull out the glow plug (4).

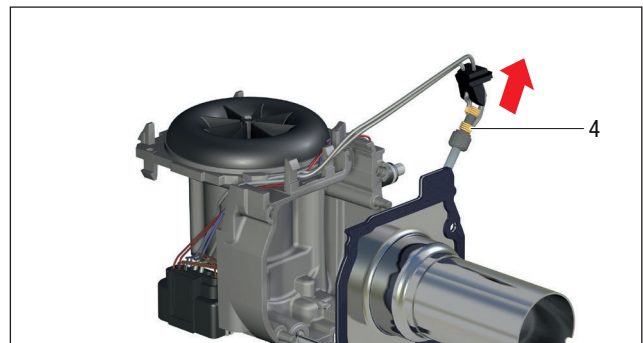

Install the combustion chamber, [see page 19](#), point 10–32.

3 REPAIR INSTRUCTIONS

REPAIR STEP 5

REMOVE THE LEAD HARNESS OF THE HEATER

i NOTE!

If the lead harness of the heater (4) is renewed, unplug the glow plug connection cables from the connector -XB4 (Chamber 3 and 4), see [Repair step 6, Page 17](#).

Apart from the flame sensor (3), the other components on the lead harness of the heater (4) (ground cable (5), water inlet sensor (2) and water outlet sensor (1)) have already been removed from the heater.

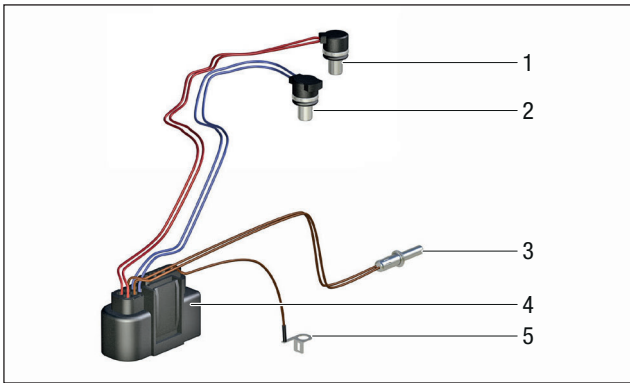

Carry out [Repair step 1](#) to [Repair step 4](#) first.

1. Unhook the flame sensor connection cables (1) from the guide hook (3) on the electric motor.
2. Remove the flame sensor (2) on the blower housing.

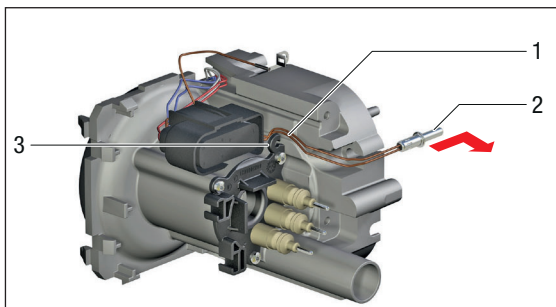

CHECK FLAME SENSOR

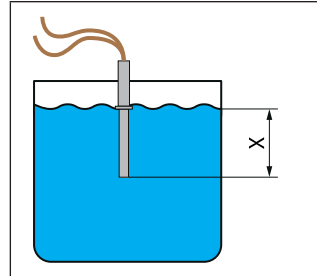

The sensor test is performed in liquid at temperatures up to max. 200 °C.

Sensor insertion depth
X = 15 mm

Use a multimeter to measure the resistance in connector -XB4 between cable BN (chamber 7) and cable BN (chamber 8). If the value lies outside the values table, replace the lead harness of the heater.

Table of values

θ [°C]	R [Ω]	θ [°C]	R [Ω]
-50	830 ±11	50	1194 ±12
0	1000 ±10	100	1385 ±15
20	1078 ±11	150	1573 ±20
25	1097 ±11	200	1758 ±24

Install the lead harness, [see page 19](#), point 7–32.

CHECK THE WATER INLET AND OUTLET SENSOR

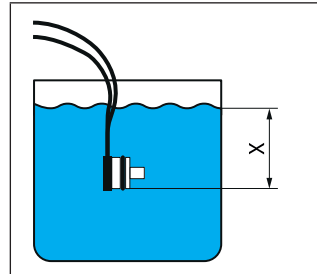

The sensor test is performed in liquid at temperatures up to max. 200 °C.

Sensor insertion depth
X = 50 mm ± 5

Check the water inlet sensor

Use a multimeter to measure the resistance in connector -XB4 between cable BU (chamber 5) and cable BU (chamber 6). If the value lies outside the values table, replace the lead harness of the heater.

Check the water outlet sensor

Use a multimeter to measure the resistance in connector -XB4 between cable RD (chamber 9) and cable RD (chamber 10). If the value lies outside the values table, replace the lead harness of the heater.

3 REPAIR INSTRUCTIONS

Table of values

θ [°C]	R [kΩ]	θ [°C]	R [kΩ]
-50	657 ±80 kΩ	80	1.26 ±100 Ω
-40	330.6 ±33 kΩ	100	0.677 ±60 Ω
-20	96.3 ±8 kΩ	120	0.389 ±38 Ω
0	32.55 ±500 Ω	150	0.183 ±20 Ω
25	10* ±11 Ω	180	0.095 ±12 Ω
40	5.33 ±320 Ω	200	0.064 ±0 Ω
60	2.49±175 Ω		

Install the lead harness, [see page 19](#), point 7–32.

REPAIR STEP 6

DISMANTLE GLOW PLUG

Carry out [Repair step 1](#) to [Repair step 5](#) first.

1. Unplug the WH connection cables from the glow plug (1) at the connector -XB4 (2) (chamber 3 and 4).

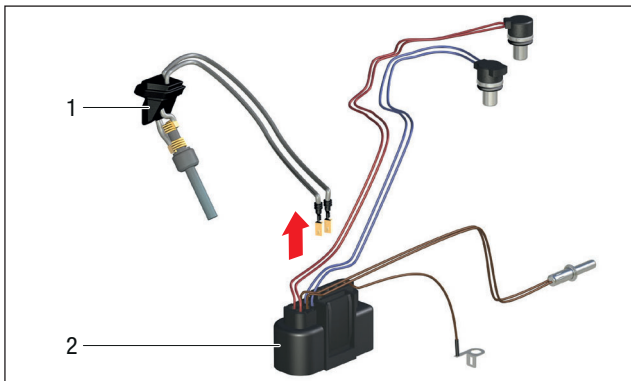

CHECK THE GLOW PLUG



Risk of burns and fire due to glowing compartment.

After the operating voltage is applied the glow plug becomes very hot and can cause burns.

→ Insert glow plug in combustion chamber or jig.

1. Apply voltage 9.5^{±0.1} volt to the glow plug
2. After 25 sec. measure the current intensity and then disconnect from the power supply.
 - > Measured value 9.5 A (+1/-1.5) the glow plug is ok
 - > Deviating values → renew the glow plug.

Install the glow plug, [see page 18](#), point 6–32.

REPAIR STEP 7

REPLACE THE BLOWER

Carry out [Repair step 1](#) to [Repair step 5](#) first.
Then replace the blower.

REPAIR STEP 8

REMOVE THE BLOWER HOUSING / HEAT EXCHANGER SEAL AND THE FUEL CONNECTION GROMMET

Carry out [Repair step 1](#) to [Repair step 4](#) first.

1. Remove the seal (1) from the combustion chamber.



The folding seal can be cut for easier removal.

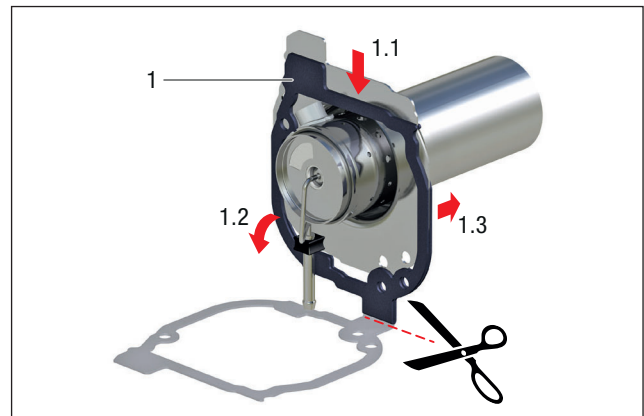

2. Pull off the fuel connection grommet (2) from underneath.

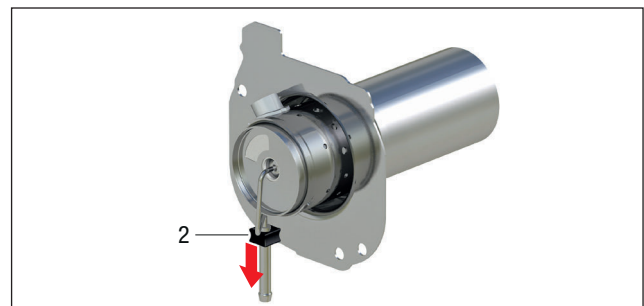

Install the blower housing / heat exchanger seal and fuel connection grommet, [see page 18](#), point 1–32.



Illustration shows the combustion chamber of a diesel heater.

3 REPAIR INSTRUCTIONS

ASSEMBLE THE HEATER

⚠ CAUTION!

Damage to unit caused by third party, damaged or deformed components

Installing third party, damaged or deformed components has a negative effect on the function of the heater.

- ➔ Replace damaged, deformed or defective components.
- ➔ Use original Eberspächer spare parts, see spare parts list.
- ➔ Use all the components included in spare parts kits.

INSTALL THE FUEL CONNECTION GROMMET AND BLOWER HOUSING / HEAT EXCHANGER SEAL

1. Push on the fuel connection grommet (1). Bottom edge of the grommet is flush with the combustion chamber flange (2).

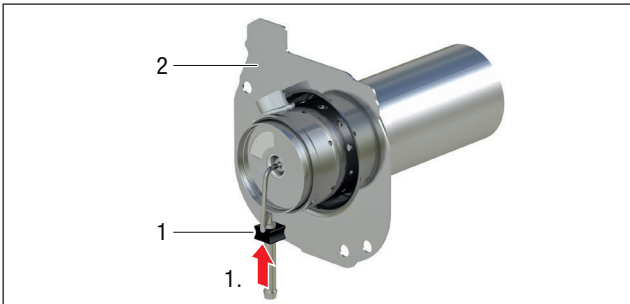

2. Before installing fold the blower housing / heat exchanger seal (3) at the connecting web (4).
3. Push the top part of the seal over the flame tube (5) up to the combustion chamber flange (2).
4. Fold the bottom part of the seal up over the fuel connection (6).

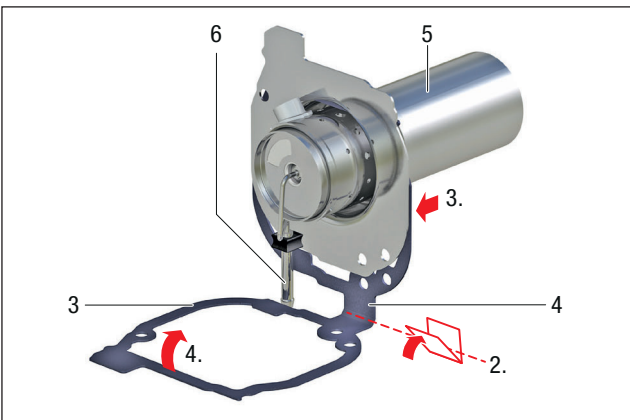

5. Hold both seal parts together and push them upwards between the combustion chamber flange (2) and the fuel connection grommet (1). The drillholes in the seal and combustion chamber lie above each other.

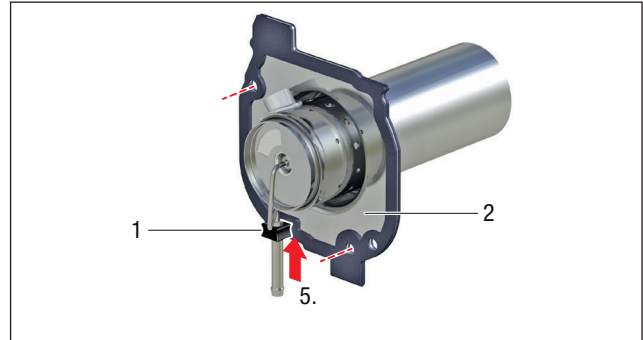

i NOTE!

Illustration shows the combustion chamber of a diesel heater.

INSTALL THE GLOW PLUG

i NOTE!

Do not twist the glow plug connection cables.

6. After replacing the glow plug (1) or lead harness of the heater (2), plug the glow plug connection cables onto connector -XB4 in chamber 3 and 4.

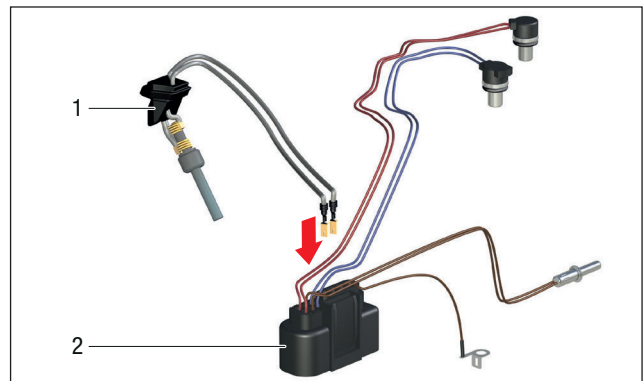

3 REPAIR INSTRUCTIONS

INSTALL THE LEAD HARNESS OF THE HEATER / FLAME SENSOR

7. Insert the flame sensor connection cables (1) in the blower housing (2).
8. Push in the flame sensor (3).
9. Hook the connection cables in the guide hook (4) on the electric motor.

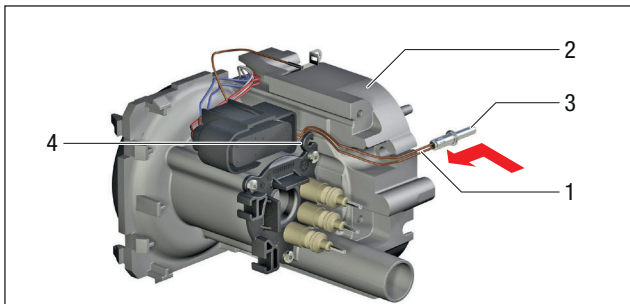

INSTALL THE COMBUSTION CHAMBER



CAUTION!

Unit damage due to unbalance!

The impeller is pressed on precisely. If the heater is put down on the blower it can cause damage to the blower.

- Do not lay heater on its impeller.
- Always put down heater to the side.

10. Insert the glow plug (2) in the combustion chamber (1). The connection cables (3) point towards the middle of the unit.
11. Place the combustion chamber on the blower housing, at the same time
 - feed the flame sensor (4) and guide pins (5) into the drillholes in the combustion chamber flange.
 - Push the glow plug grommet (6) and fuel connection grommet (7) into the corresponding recesses in the blower housing.
12. Check the fit of the grommets. The grommets must be completely pushed in.

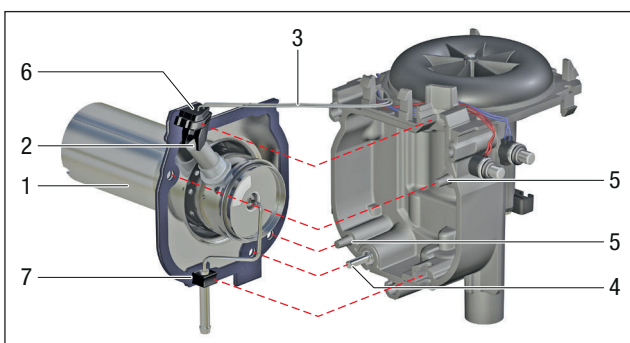

INSTALLING THE HEAT EXCHANGER

13. Position the heat exchanger (1) on the flame tube and guide pins.
14. Fix heat exchanger with thread-forming screws (2) M5 × 65. Tightening torque 7.5^{+0.7} Nm.
15. Lay the glow plug connection cables (3) parallel in the guides, do not twist.

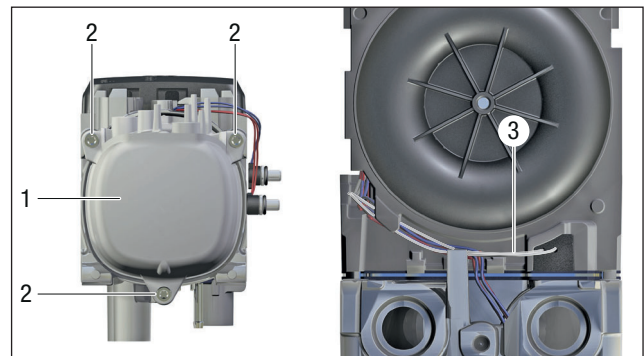

INSTALL THE WATER INLET SENSOR / WATER OUTLET SENSOR



NOTE!

- If the lead harness of the heater is re-used, always renew the O rings of the sensor.
- If the lead harness of the heater has been renewed, grease the O-rings of the sensor.

16. Insert the water inlet sensor (1) (cables BU) in the holder (2).
17. Insert the water outlet sensor (3) (cables RD) in the holder (4).
18. Lay the sensor connection cables (5) in the guides as shown.

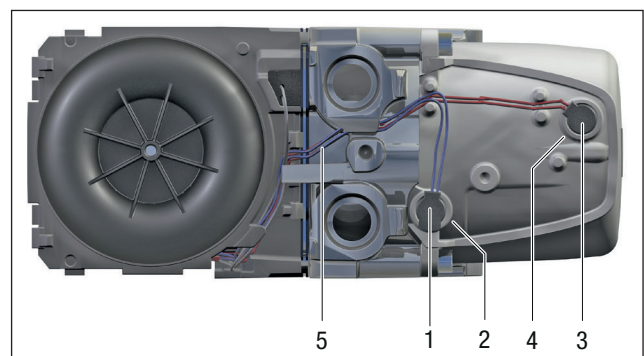

3 REPAIR INSTRUCTIONS

19. Check the sensor compression spring (6) for damage and deformation. Renew damaged or deformed compression spring.
20. Position the compression spring as shown and fix with thread-forming screw (7) M4 × 10. Tightening torque 3.8^{±0.4} Nm.

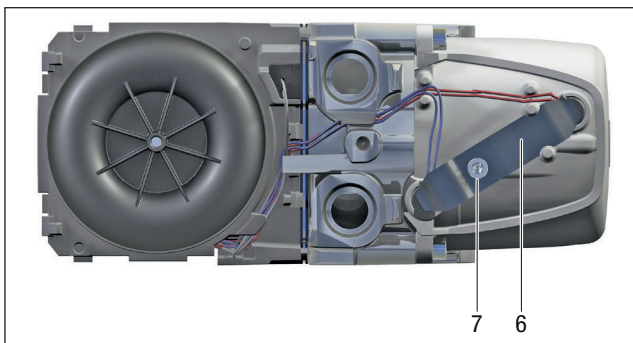

INSTALL WATER CONNECTION SOCKET / SENSOR COVER

i NOTE!

- The sensor cover together with the screw is not a tool for pushing the water connection socket into the heat exchanger.
- Check the O-rings of the water connection socket for damage.
- Replace O-rings.

21. Insert the water connection socket (1) in the sensor cover (2). The teeth (3) engage in each other.
22. Insert the water connection socket in the holders (4) on the heat exchanger and press in, until the teeth sit on the heat exchanger.
23. If using an elbow socket, set the required direction.
24. Push the sensor cover downwards and readjust the connection socket position until the teeth (3) engage once again.
25. Fix the sensor cover with thread-forming screw (5) M5 x 18. Tightening torque 6.5^{±0.5} Nm.

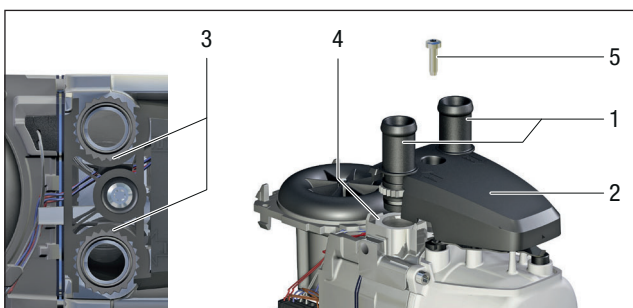

MOUNTING THE CONTROL BOX

⚠ CAUTION!

Damage to unit due to overload

An excessive tightening torque on the screw (12) overloads and damages the control box housing and causes malfunctions.

→ Keep to the specified tightening torque.

26. Insert the ground cable (1) in the holder (2) on the control box (3).
27. Push the connector (4) of the heater lead harness into the control box connection (5), until the locking device (6) snaps into position.
28. Feed the guides (7) on the electric motor into the rails (8) on the control box.
29. Push the control box (3) upwards. The snap connections (10) latch onto the blower housing (11).
30. Fix the control box with 2 thread-forming screws (12) M4 × 10. Tightening torque 2.8^{±0.3} Nm.
31. Stow away the cables and push in the electric motor cover (9) from above.

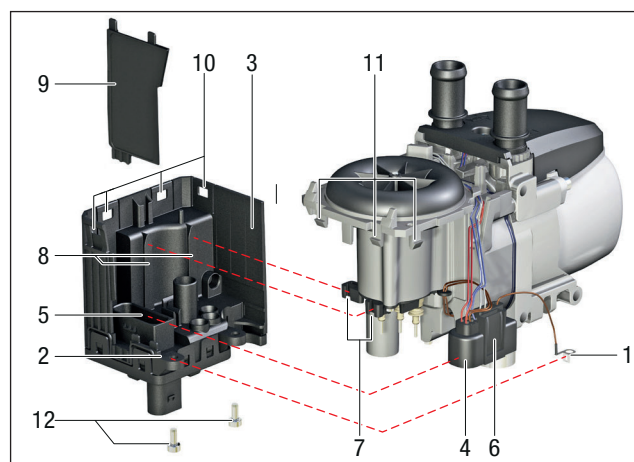

INSTALLING THE BLOWER COVER

32. Place the blower cover (1) on the blower housing (2) and push downwards, until the snap connections (3) latch into position.

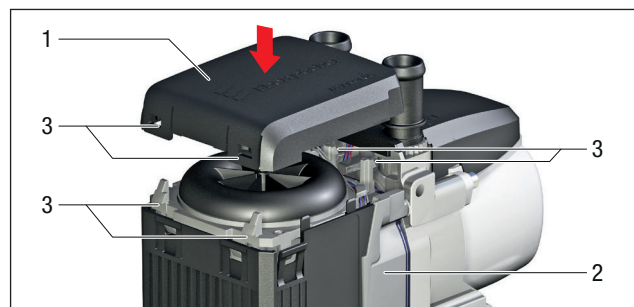

3 REPAIR INSTRUCTIONS

MEASURING THE FUEL QUANTITY

PREPARING FOR THE MEASUREMENT

- Pull off the fuel pressure line from the heater and insert in a measuring cylinder (size 25 cm³).
- Switch on heater.
- Depending on the heater type, the metering pump starts pumping fuel after 17 to 20 sec. If the fuel comes out uniformly and free of bubbles, the fuel line is filled and vented.
- Switch off heater and empty measuring cylinder.

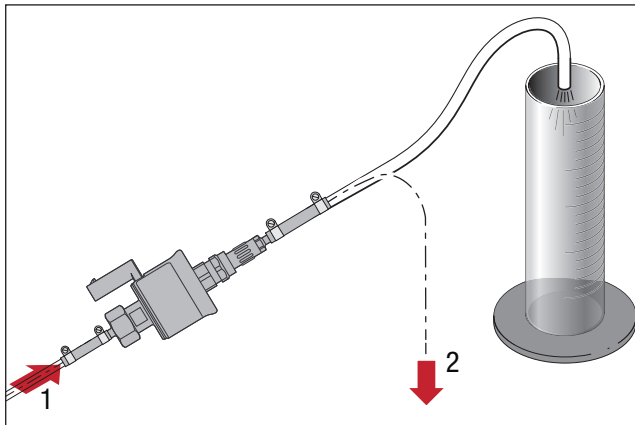

- 1 from the fuel tank
- 2 to the heater

MEASUREMENT

- Switch on heater.
- Depending on the heater type, the metering pump starts pumping fuel after 17 to 20 sec.
- During the measurement, hold the measuring cylinder at the level of the heater.
 - After starting once, two automatic start repeats must take place to obtain sufficient fuel for the measurement.
- After measuring, switch off the heater.
- Read off the quantity of fuel in the measuring cylinder.

EVALUATION

- Compare the measured quantity of fuel with the values in the following table.
- Measured fuel quantity above the maximum value or below the minimum value → replace the metering pump.

Heater type	Hydronic S3	
Heater version	B 4 E / B 5 E	D 4 E / D 5 E
Discharge period		
one-off start	75 sec.	86 sec.
Fuel quantity, nominal [cm ³]	8.9	7.0
Fuel quantity - max. [cm ³]	9.8	7.35
Fuel quantity - min[cm ³]	8.0	6.65

i NOTE!

The given fuel quantities result from the initial start of the heater. Carry out the fuel measurement only if the battery is sufficiently charged. During the measurement at least 12 volt or max. 13 volt should be applied to the control box.

MEASURING THE FUEL QUANTITY, WITH EASYSCAN

PREPARATION / MEASUREMENT / EVALUATION

- Remove the fuel pipe at the heater and discharge the fuel into a measuring cylinder (size 25 cm³).
- Make the connection between the heater and EasyScan diagnostic interface VCI. To do this, connect the EasyScan to the diagnostics connector of the cable harness.
- Start the EasyScan diagnostics software.
- In the “Diagnosis” menu, open the [Component activation] tab.
- Call up the [External components] submenu.
- Enter this test parameter in the [Metering pump] menu:
 - Frequency: 7 Hz
 - Duration: 60 seconds
- Press the [Start metering pump] button to start the measurement.
- Wait until the measurement process has ended, then read off the pumped quantity of fuel in the measuring centre.
- If the measured quantity of fuel lies outside the values listed in the table, the metering pump must be replaced.

Heater type	Hydronic S3	
Heater version	B 4 E / B 5 E	D 4 E / D 5 E
Delivery period in sec.	60 sec.	60 sec.
Fuel quantity, nominal [cm ³]	11,4	12,4
Fuel quantity - max. [cm ³]	12,5	13,6
Fuel quantity - min[cm ³]	10,3	11,2

3 REPAIR INSTRUCTIONS

HYDRONIC S3 ECONOMY COMPONENT DRAWING

PARTS LIST

- 1 Jacket and heat exchanger
- 2 Control box
- 3 Blower
- 4 Combustion chamber
- 5 Cover, blower
- 6 Cover, sensor
- 7 Water connection socket, straight
- 8 Glow plug
- 9 Heater lead harness with water inlet sensor, water outlet sensor, ground cable and flame sensor
- 10 Compression spring
- 11 Screw, thread-forming, M5 × 65 (3x)
- 12 Cover, electric motor
- 13 Screw, thread-forming, M4 × 10 (2x)
- 14 O-ring, 16 x 2
- 15 Water connection socket, angled
- 16 Screw, thread-forming M5 × 18
- 17 O-ring, 7.5 × 2 (2x)
- 18 Seal, heat exchanger / blower
- 19 Grommet, fuel pipe
- 20 Cover, electric motor
- 21 Screw, M3 × 12 (3x)

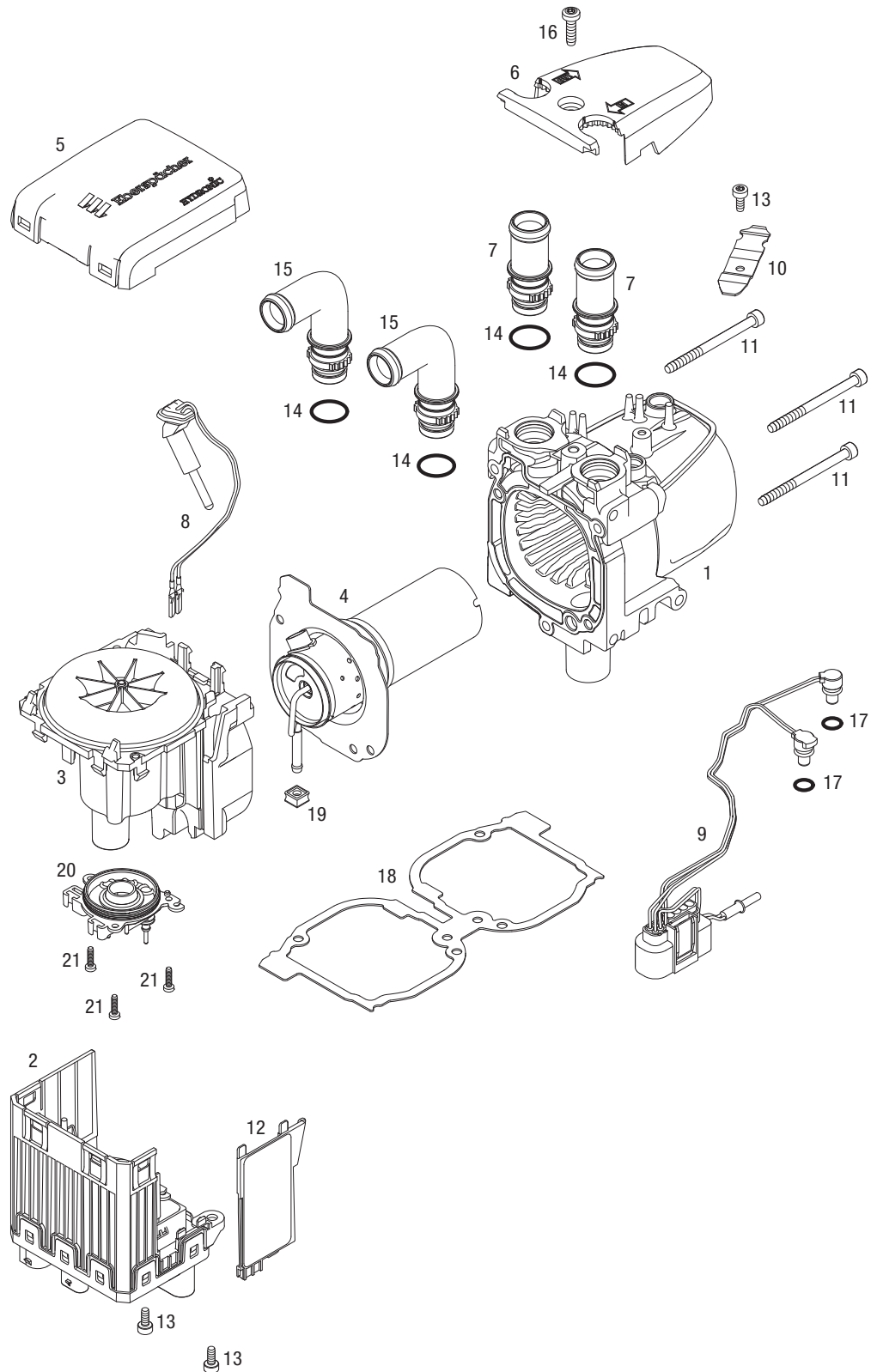

4 ELECTRICS / CIRCUIT DIAGRAM

HEATER WIRING



CAUTION!

Unit damage due to improper electrical connection

The heater is to be connected up electrically according to the EMC directives. Improper interventions can affect the EMC.

- Do not damage the insulation of electrical cables.
 - Avoid chafing, kinking, jamming or exposure to heat.
- Close off unused chambers of watertight connectors with filler plugs.
- Make the electrical corrosion-free and securely.



NOTE!

Note the following for the electrical wiring of the heater and the control unit:

- Position electrical cables and components in the vehicle so that they can function properly under normal operating conditions without impairment (e.g. due to heat exposure, moisture, etc.).
- Use correct cable cross-section between the battery and heater.
 - For a cable length up to 6 m (positive and negative cable) the minimum cable cross-section is 4 mm².
 - If the positive cable is connected to the fuse box (e.g. terminal 30), the vehicle's cable from the battery to the fuse box must be included in the calculation of the total cable length.
- Insulate unused cable ends.
- For circuit diagrams for the EasyStart control unit refer to the installation instructions of the control unit or the "Installation Instructions plus – EasyStart / Altitude Kit, Special Functions and Diagnosis", which are available to read and download from www.eberspaecher-standheizung.com/download.

PARTS LIST FOR CIRCUIT DIAGRAM, HEATER AND CABLE HARNESS

-A10	Control box
-A30	Fuse holder, 3 pin
-B5	Flame sensor
-B10	WAF (water outlet sensor)
-B11	WEF (water inlet sensor)
-F1	Fuse, heater
-F2	Fuse, control unit
-F3	Fan relay fuse
-K1	Fan relay
-M3	Burner motor
-M10	Water pump
-R1	Glow plug
-R2	Terminating resistor 120 Ω
-R3	Terminating resistor 9.2 kΩ
-X1	Ring terminal end
-XB1	Bush housing, heater power supply
-XB2	Bush housing, heater signals
-XB3	Bush housing, heater water pump
-XB6/1	EasyScan bush housing
-XB6/3	EasyFan bush housing
-XB7	Relay block
-XB8/1	Bush housing, metering pump plug-in connection
-XB8/2	Bush housing, water pump
-XS6/1	Mating connector with terminating resistor
-XS8	Connector housing, metering pump plug-in connection
-Y1	Fuel metering pump
a	to the heater
b	Activation, vehicle fan
c	to the cable harness
d	to the control unit
e	EasyScan connection
f	EasyFan connection

CABLE COLOURS

RD	red	GR	grey	BK	black
BU	blue	YE	yellow	GN	green
WH	white	VT	violet	BN	brown

4 ELECTRICS / CIRCUIT DIAGRAM

HEATER CIRCUIT DIAGRAM

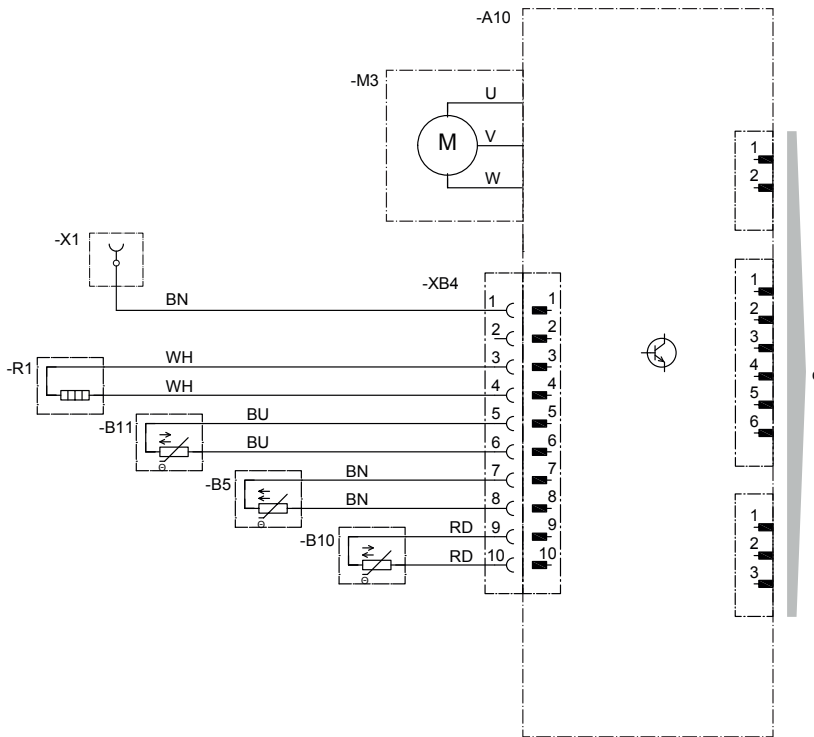
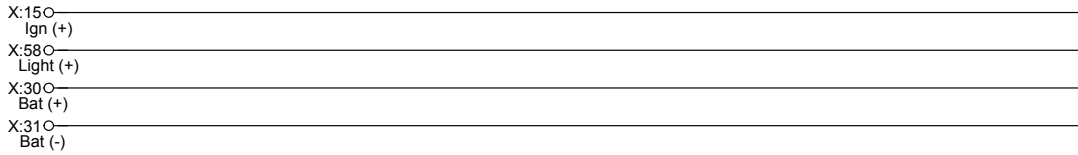

4 ELECTRICS / CIRCUIT DIAGRAM

CABLE HARNESS CIRCUIT DIAGRAM

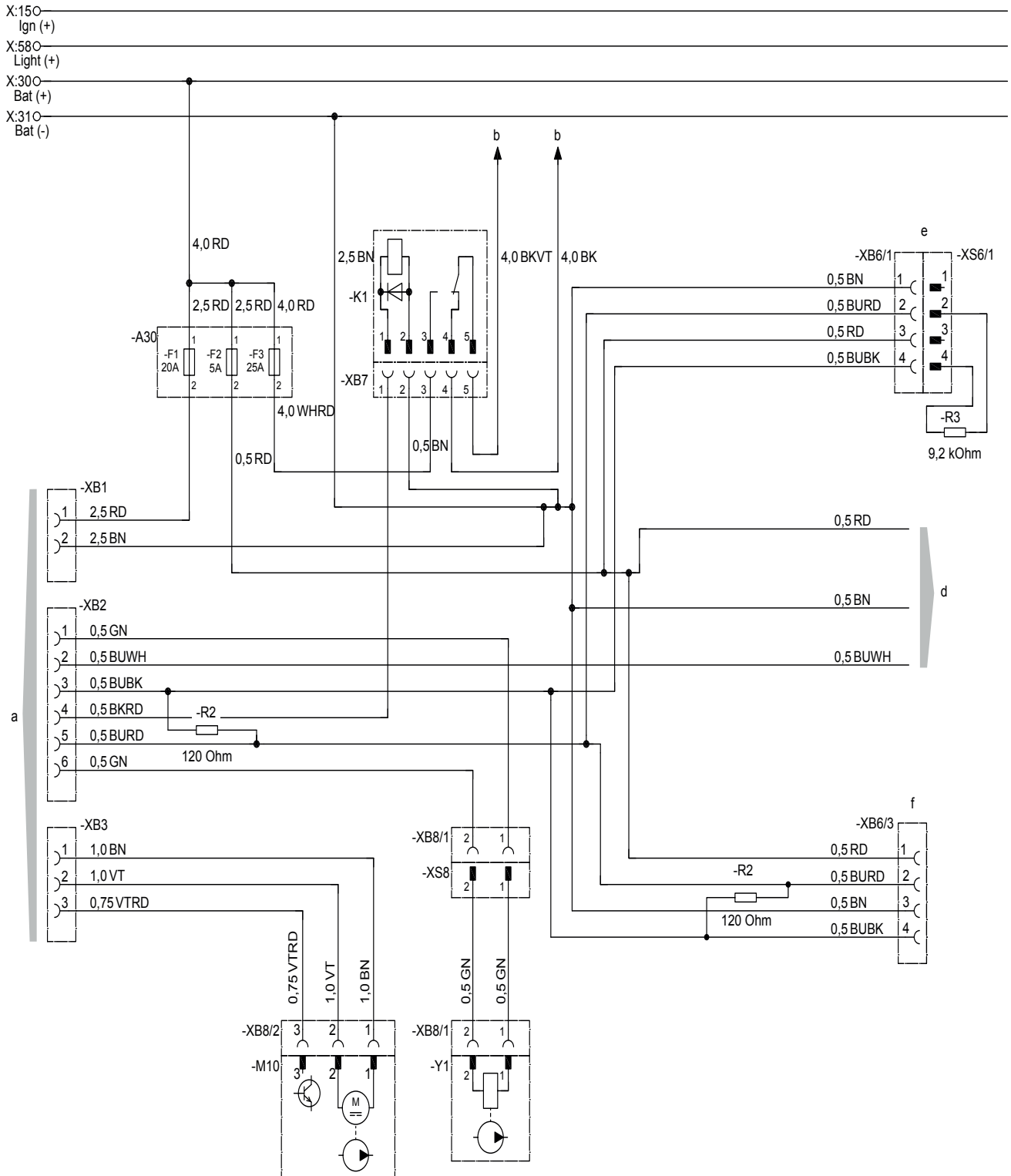

5 TECHNICAL DATA

PETROL HEATER

Type	Hydronic S3			
Version	B 4 E		B 5 E	
Heating medium	Mixture of water and anti-freeze (Proportion of antifreeze at least 10 % up to 50 % maximum)			
Fuel	Petrol – standard commercially available (DIN 51600 and EN 228)			
Rated voltage [V]	12			
Control stage	Maximum	Minimum	Maximum	Minimum
Heat flow [W]	4300	1800	5000	1800
Fuel consumption [l/h]	0.57	0.23	0.67	0.23
Average electrical power consumption [W]	during operation	24	7	32
	while starting	135		
Operating voltage [V]	minimum	10.5		
	maximum	16.0		
Allowable operating pressure [bar]	< 2.5 bar overpressure			
Water volume in the heater [l]	approx. 0.09			
Minimum water flow rate [l/h]	> 300			
Allowable ambient temperature [°C] (Also note and follow the information for installation of the heater and metering pump!)	Heater	during operation	– 40 to +60	
		without operation	– 40 °C to +105 °C, short-term +125 °C (5 x 2h)	
	Metering pump	during / without operation	– 40 °C to +20 °C	
		Storage	– 40 °C to +105 °C	
	drawn-in combustion air	max. +25 °C, short-term +45 °C (15 minutes)		
Interference suppression class	5 (EN 55025)			
Weight – without coolant liquid and additional parts [kg]	approx. 2.0			
Degree of protection DIN 40050, Part 9	Heater (in operation)		IP5K6K	
	Heater (not in operation)		IP5K9K	

WATER PUMP

Rated voltage [V]	12
Electrical power consumption [W]	18
Delivery rate [l/h]	600
Delivery pressure difference [bar]	0.15



CAUTION

Damage to unit due to impermissible operation

Operating the heater outside the technical data can cause malfunctions.

→ Comply with the technical data.



NOTE

Provided no other values are given, the technical data provided is with the usual tolerances of $\pm 10\%$ at rated voltage, 20 °C ambient temperature and reference altitude Esslingen.

5 TECHNICAL DATA

DIESEL HEATER

Type	Hydronic S3			
Version	D 4 E		D 5 E / D 5 E CI-Bus	
Heating medium	Mixture of water and anti-freeze (Proportion of antifreeze at least 10 % up to 50 % maximum)			
Fuel	Diesel – standard commercially available (EN 590) Blending with max. 20 % FAME according to EN 14214 is permitted.			
Rated voltage [V]	12			
Control stage	Maximum	Minimum	Maximum	Minimum
Heat flow [W]	4300	1300	5000	1300
Fuel consumption [l / h]	0.53	0.15	0.59	0.15
Average electrical power consumption [W]	during operation	27	5	32
	while starting	135		
Operating voltage [V]	minimum	10.5		
	maximum	16.0		
Allowable operating pressure [bar]	< 2.5 bar overpressure			
Water volume in the heater [l]	approx. 0.09			
Minimum water flow rate [l / h]	> 300			
Allowable ambient temperature [°C] (Also note and follow the information for installation of the heater and metering pump!)	Heater	during operation	– 40 to +80	
		without operation	– 40 °C to +105 °C, short-term +125 °C (5 x 2h)	
	Metering pump	during / without operation	– 40 °C to +20 °C	
		Storage	– 40 °C to +105 °C	
	drawn-in combustion air		max. +25 °C, short-term +45 °C (15 minutes)	
Interference suppression class	5 (EN 55025)			
Weight – without coolant liquid and additional parts [kg]	approx. 2.0			
Degree of protection DIN 40050, Part 9	Heater (in operation)		IP5K6K	
	Heater (not in operation)		IP5K9K	

WATER PUMP

Rated voltage [V]	12
Electrical power consumption [W]	18
Delivery rate [l / h]	600
Delivery pressure difference [bar]	0.15



CAUTION

Damage to unit due to impermissible operation

Operating the heater outside the technical data can cause malfunctions.

→ Comply with the technical data.



NOTE

Provided no other values are given, the technical data provided is with the usual tolerances of $\pm 10\%$ at rated voltage, 20 °C ambient temperature and reference altitude Esslingen.

6 ENVIRONMENT

CERTIFICATIONS

The high quality of Eberspächer products is the key to our success. To guarantee this quality, we have organised all work processes in the company along the lines of quality management (QM). Even so, we still pursue a large number of activities for continuous improvement of product quality in order to keep pace with the similarly constantly growing requirements made by our customers.

All the steps necessary for quality assurance are stipulated in international standards.

This quality is comprehensive. It affects products, procedures and customer / supplier relationships.

Officially approved public experts assess the system and the corresponding certification company awards a certificate.

Eberspächer Climate Control Systems GmbH has already qualified for the following standards:

**Quality management in accordance with
EN ISO 9001:2000 and ISO / TS 16949:1999**

**Environmental management system in accordance with
EN ISO 14001:1996**

DISPOSAL

DISPOSAL OF MATERIALS

Old units, defective components and packaging materials can be separated into their individual materials so that if necessary all parts can be disposed of in an environmentally friendly way or can be recovered and reused.

Electric motors, control boxes and sensors (e.g. temperature sensors) are deemed to be “electronic scrap”.

DISMANTLING THE HEATER

The heater is dismantled according to the repair steps in this documentation.

PACKAGING

The packaging of the heater can be kept in case the heater has to be sent back.

7 SERVICE

STANDARD TIMES

The standard times important for the guarantee are summarised in the following overview. The standard times are given as a work value.

1 work value (AW) = 6 minutes

The standard times are based on well-equipped garages/workshops and include all material and personal allowances taking into account the safety regulations.

Guarantee / warranty work must be carried out within these standard times.

PARTS TO BE REMOVED

DEFECTIVE COMPONENT	WORK VALUE (AW)	Control box	Electric motor cover	Sensor cover	Water connection socket / O-ring	Compression spring	Water inlet and outlet sensor / O-ring	Heat exchanger	Combustion chamber	Blower cover	Heater lead harness	Glow plug	Blower	Combustion chamber seal	Fuel pipe grommet
Control box	1	•	•												
Electric motor cover	1	•	•												
Sensor cover	1			•											
Water connection socket / O-ring	1			•	•										
Compression spring	1			•	•	•									
Water inlet and outlet sensor / O-ring	1			•	•	•	•								
Heat exchanger	1			•	•	•	•	•							
Combustion chamber	2			•	•	•	•	•	•	•	•	•		•	•
Blower cover	2			•	•										
Heater lead harness	2	•	•	•	•	•				•	•	•			
Glow plug	2	•	•	•	•	•	•	•	•	•	•	•		•	•
Blower	2	•		•	•			•	•	•	•		•	•	•
Combustion chamber seal	2			•	•	•	•	•	•	•	•	•		•	•
Fuel pipe grommet	2			•	•	•	•	•	•		•	•		•	•

PERIPHERAL REPAIR WORK

Diagnosis, fault memory, functional check	4
Fuel metering pump	2
Control unit	3
Water pump	4
Exhaust pipe	1.5
Exhaust silencer	2.5
Combustion air silencer	2
Combustion air hose	2
Replace the main fuse	1
Replace the combination valve	4
Replace the non-return valve	4

7 SERVICE

INDEX

A

- Accident prevention [5](#)
- Ambient temperature [26 – 27](#)
- Assemble the heater [18](#)

C

- Cause [7](#)
- Certifications [28](#)
- Check the water inlet sensor [16](#)
- Check the water outlet sensor [16](#)
- Circuit diagram, cable harness [25](#)
- Component drawing [22](#)
- Contents [2 – 4](#)
- Control box dismantling kit [12](#)
- Control box is locked [6](#)
- Control stage [26 – 27](#)

D

- Delivery pressure difference [26 – 27](#)
- Delivery rate [26 – 27](#)
- Dismantle the heater [13](#)
- Dismantling the heater [28](#)
- Disposal [28](#)
- Disposal of materials [28](#)

E

- EMERGENCY OFF [5](#)
- Emergency stop [5](#)
- Environmental management system [28](#)
- EU Declaration of Conformity [31](#)
- External diagnostics system [6](#)

F

- Fault code table [7](#)
- Fault description [7](#)
- Fault diagnosis [6](#)
- Faults [6](#)
- Fuel [26 – 27](#)
- Fuel consumption [26 – 27](#)
- Fuel quantity [21](#)
- Functional check [5](#)

G

- General information [5](#)
- Guarantee [5](#)

H

- Heater circuit diagram [24](#)
- Heat flow [26 – 27](#)
- Heating medium [26 – 27](#)

I

- Installation Instructions Plus [5](#)
- Installation recommendation [5](#)
- Install the glow plug [18](#)
- Interference suppression class [26 – 27](#)

L

- Liability [5](#)

M

- Minimum water flow rate [26 – 27](#)

O

- Operating pressure [26 – 27](#)
- Operating voltage [26 – 27](#)
- Other applicable documents [5](#)

P

- Packaging [28](#)
- Parts list [23](#)
- Parts list, circuit diagram, cable harness [23](#)
- Parts list, circuit diagram, heater [23](#)
- Power consumption [26 – 27](#)

Q

- Quality management [28](#)

R

- Rated voltage [26 – 27](#)
- Release tool [12](#)
- Remedial action [7](#)

S

- Safety instructions [5](#)
- Spare parts list [5](#)
- Special tool [12](#)

T

- Technical description [5](#)
- Testing equipment/control units [6](#)

U

- Unlock the control box [6](#)

W

- Water pump [26 – 27](#)
- Weight [26 – 27](#)
- Wiring [23](#)

7 SERVICE

LIST OF ABBREVIATIONS

EMC DIRECTIVES

Electromagnetic compatibility.

FAME

Biodiesel to EN 14214.
